

NEW DEUTZ DRIVE SERIES TD 2.2 POWER PACK



TD 2.2 L3 ENGINE OVERVIEW

- ▶ Newly designed, 3-cylinder engine with cooled external exhaust gas recirculation.
- ▶ The Powerpack comes complete with cooling system, exhaust system and optional control system. This simplifies machine integration for the OEM considerably and virtually means a drop-in solution.
- ▶ With its powerful DEUTZ Common Rail (DCR®) injection system and electronic drive system control, the TD 2.2 delivers optimum performance while consuming less fuel.
- ▶ Additionally, its long oil change intervals and easy-to-change engine fluids make maintenance a breeze, resulting in reduced running costs and increased machinery availability.

APPLICATIONS

DEUTZ Power Packs offer the renowned performance and reliability associated with all DEUTZ engines and powered equipment. They're ideal for use in a wide range of equipment including:

- ▶ De-watering pumps
- ▶ Woodchippers
- ▶ Aircraft ground-support equipment
- ▶ Small agricultural machinery
- ▶ Construction machinery
- ▶ Irrigation pumps
- ▶ Trenching equipment
- ▶ Welders
- ▶ Scissor lifts

Elevate your equipment's performance and longevity by choosing DEUTZ genuine spare parts only.



ENGINE DATA

No. of cylinders		3
Bore/stroke	mm	92/110
Displacement	l	2.2
Power maximum	kW	44.5
Power rating for interm. operations	kW	36.4
Power rating for cont. operations	kW	26
Max normal speed	min-1	2600
Max. torque @ 1600 rpm	Nm	205
Specific fuel consumption ¹	g/kWh	236
Adapter housing		SAE 4
Flywheel		SAE 8" & 10"

1) Best point consumption refers to diesel with a density of 0.835 kg/dm³ at 15°C

DIMENSIONS

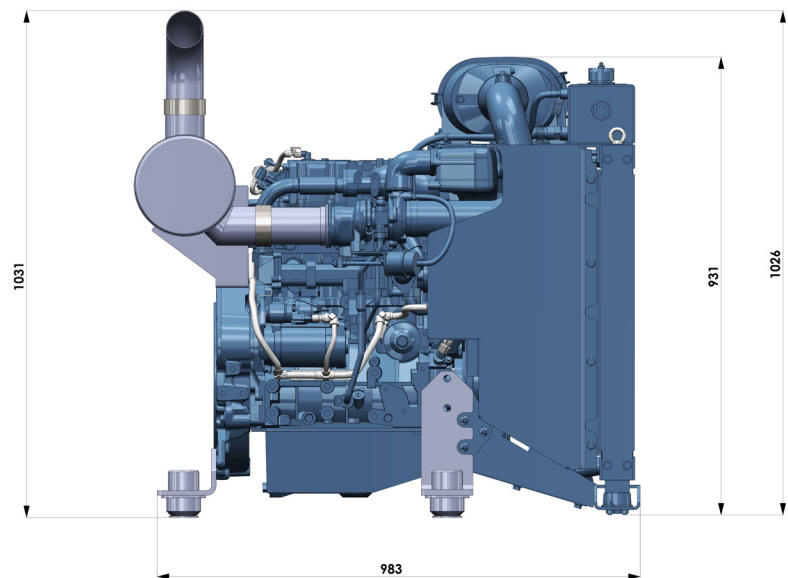
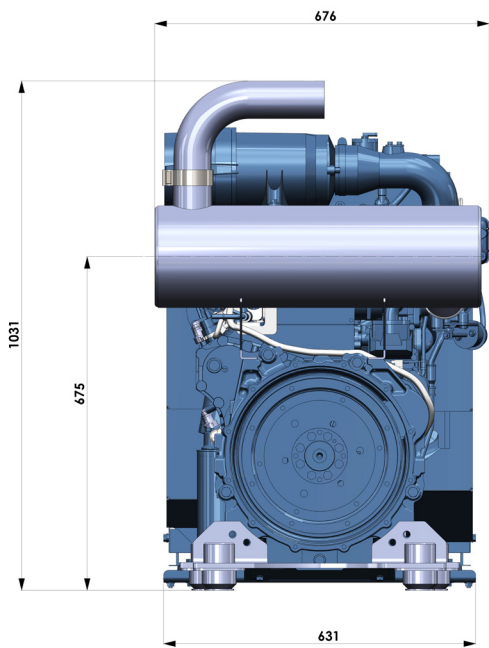

ENGINE PERFORMANCE CURVE

Engine type / - code:	TD 2.2 L3		
Rated power:	26 kW	36.4 kW	44.5 kW
Max. torque:	130 Nm @ 1600 rpm	180 Nm @ 1600 rpm	205 Nm @ 1600 rpm

Power Curves TD 2.2 L3

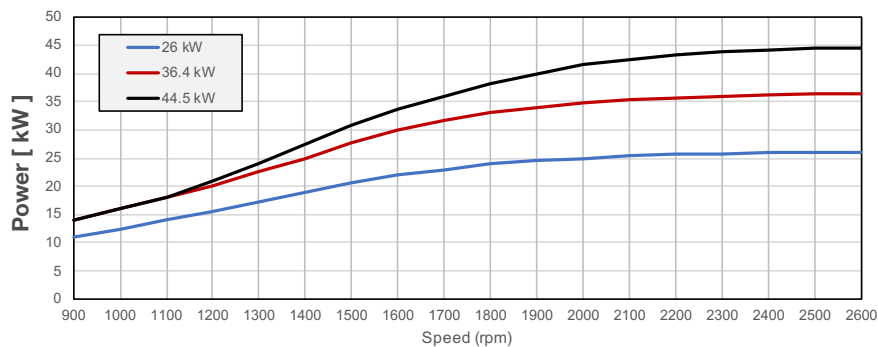

- Values after 100 running-in hours under load conditions.
- Values derived are from currently available data.
- Errors and omissions excepted.

Elevate your equipment's performance and longevity by choosing DEUTZ genuine spare parts only.

